



STRAPPING HEADS

# TR2000



MODULAR SERIES

## 🇬🇧 Applications



Paper



Cardboard



Plastic/Cans



Glass

# TR2000

TR2000\_EN

The TR2000 is a model of the Modular Series developed by OMS and represents the state-of-the-art in the field of strapping heads. The main features allow a rapid exchange of the modular groups, allowing production to be maintained and any downtime minimised. The Welding group, for example, can

be replaced in only 2 minutes while the Clamping group in 4 minutes. Thanks to high quality of mechanics and electronics components as well as proven and reliable Tensioning Technology used, the TR2000 gives a top quality sealing, fast feed and consistent alignment of the strap.

## Technical data

Strap	
Type of strap	Polyester (PET)
Width	16 ÷ 19 mm
Thickness	0,8 ÷ 1,3 mm
Tensioning	Up to 7000 N
Max feeding and recovery speed	2,7 m/s
Utilization temperature	-10° ÷ +50° C
Noise level	< 70 dB

## Options:

- > Strap refeeding device
- > Automatic strap feeding

## Advantages

- Quick Modular Groups Replacement
- High Performance and Speed
- Proven and reliable Tensioning Technology
- Fast, consistent strap feed and alignment

## Dimensions

L	735 mm
W	290 mm
H	300 mm
Weight	90 kg

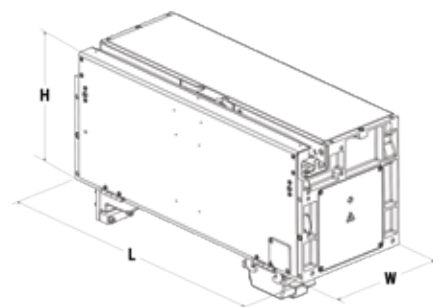

Detail of fast replacement of Welding Group.



Officina Meccanica Sestese S.p.A.

Via Borgomanero, 44 - 28040 Paruzzaro (NO)

Tel. +39 0322 541411 Fax +39 0322 53157

www.omsspa.com

info@omsspa.com

As a part of our policy of continuous improvement, we reserve the right to alter design and specifications without prior notice. This brochure is for descriptive purpose only. Some of the items pictured in this brochure are optional and not standard equipment.