



STRAPPING HEADS

TR1400



MODULAR SERIES



Applications



Paper



Cardboard



Plastic/Cans



Glass

TR1400

TR1400_EN

The TR1400 is a model of the Modular Series developed by OMS and represents the state-of-the-art in the field of strapping heads. The main features allow a rapid exchange of the modular groups, allowing production to be maintained and any downtime minimised. The Welding group, for example, can be replaced in only 2 minutes

while the Clamping group in 4 minutes. Thanks to high quality of mechanics and electronics components as well as proven and reliable Tensioning Technology used, the TR1400 gives a top quality sealing, fast feed and consistent alignment of the strap and guarantees reliable binding in PP or PET.

Technical data

Strap	
Type of strap	Polyester (PET) Polypropylene (PP)
Width	9 ÷ 16 mm
Thickness	0,6 ÷ 1,0 mm
Tensioning	Up to 2300 N
Max feeding and recovery speed	5,5 m/s
Utilization temperature	-10° ÷ +50° C
Noise level	< 70 dB

Options:

- > Strap refeeding device
- > Automatic strap feeding

Advantages

- Quick Modular Groups Replacement
- High Performance and Speed
- Proven and reliable Tensioning Technology
- Fast, consistent strap feed and alignment

Dimensions

L 735 mm
W 290 mm
H 300 mm
Weight 90 kg

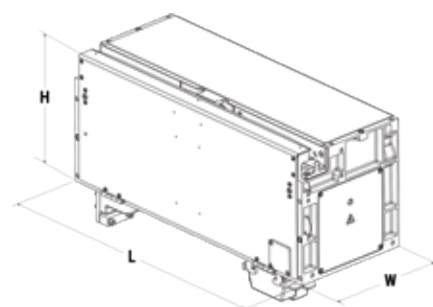

The head is available in two different models: Standard and **TR1400HD** version (with blade cleaning system and knurled pliers).



Detail of fast replacement of Clamping Group.



Detail of fast replacement of Welding Group.



Officina Meccanica Sestese S.p.A.

Via Borgomanero, 44 - 28040 Paruzzaro (NO)

Tel. +39 0322 541411 Fax +39 0322 53157

www.omsspa.com

info@omsspa.com

As a part of our policy of continuous improvement, we reserve the right to alter design and specifications without prior notice. This brochure is for descriptive purpose only. Some of the items pictured in this brochure are optional and not standard equipment.