

MOD.

PBTR
REEL HOLDER
WITH ROTATING
TURNABLE

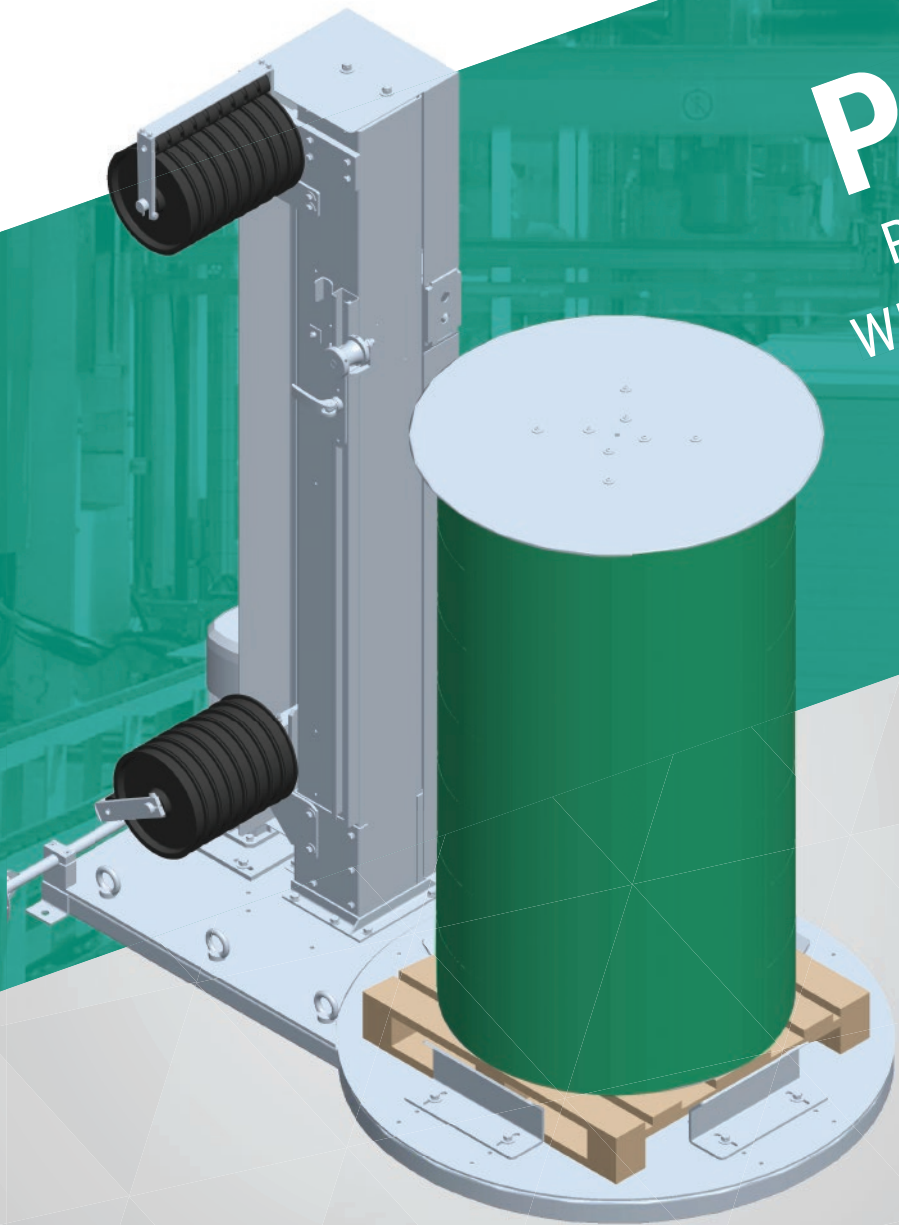

 **Applications**



Construction



Paper



Cardboard



Plastic/Can



Glass



Wood

PBTR Reel holder with rotating table

PTBR_EN

The PBTR reel holder has been designed to speed up strap replacement operations. The equipment is fitted with a motorized rotating table that allows to load pallet with five different

sizes and diameters of reels and a control panel to manage operations. Pallet of coils can be loaded with forklift or manual transpallet through loading ramp (optional).

Technical data

Power supply

| | |
|-----------------|-----------------------|
| Voltage | 400 V (+/-10%) - 50Hz |
| Installed power | ~ 1,1 kW |

Coil data

| | |
|----------------------|--------|
| Max. number loadable | 5 |
| Max. load weight | 600 Kg |

Rotating table

| | |
|----------------|-----------|
| Diameter | ø 1100 mm |
| Rotation speed | 19,8 rpm |

➤ Loading ramp for manual transpallet (Optional)

Standard machine dimensions

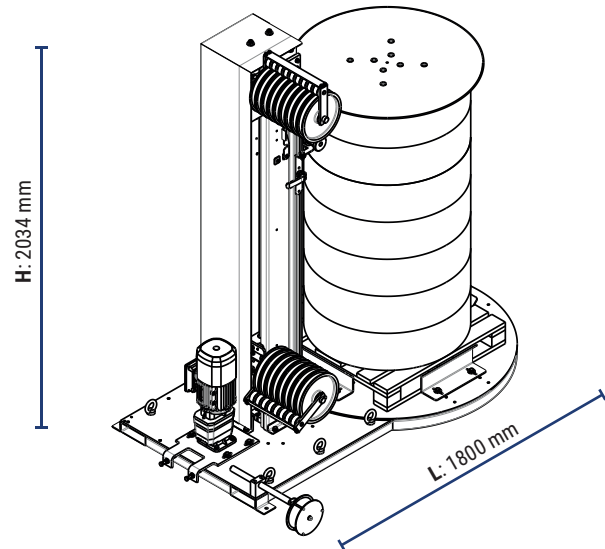

| JUMBO COIL Strap | | S.JUMBO COIL Strap | |
|------------------|-----------------|--------------------|-----------------|
| Dimensions | Meters per reel | Dimensions | Meters per reel |
| 15,5 X 0,90 | 3810 | 19,0 X 0,85 | 7200 |
| 15,6 X 0,95 | 3700 | 19,0 X 0,95 | 6400 |
| 16,0 X 0,80 | 4200 | 19,0 X 1,00 | 6000 |
| 16,0 X 1,00 | 3400 | 19,0 X 1,20 | 5000 |
| 19,0 X 0,85 | 3400 | 25,0 X 0,80 | 5800 |
| 19,0 X 0,95 | 3000 | 25,0 X 1,00 | 4600 |
| 19,0 X 1,00 | 2900 | 25,0 X 1,27 | 3600 |
| 19,0 X 1,20 | 2400 | 32,0 X 1,00 | 3600 |
| 25,0 X 0,80 | 2700 | 32,0 X 1,27 | 2800 |
| 25,0 X 1,00 | 2200 | | |
| 25,0 X 1,27 | 1700 | | |
| 32,0 X 1,00 | 1700 | | |
| 32,0 X 1,27 | 1300 | | |

| Coil size | |
|---------------|-----------------------------|
| Type of Strap | Dimensions OD x ID x H (mm) |
| JUMBO | 750 x 406 x 190 |
| S.JUMBO | 950 x 406 x 250 |

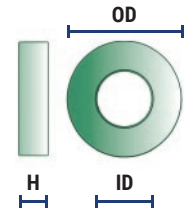

| Pack sizes | |
|---------------------------|---------------------------|
| Strap type / Nr. of reels | Dimensions L x W x H (mm) |
| JUMBO / 5 | 750 x 750 x 1100 |
| S.JUMBO / 4 | 950 x 950 x 1100 * |

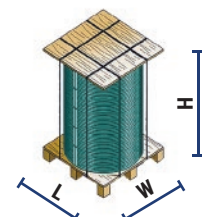

* Wood pallet must be adapted to be loaded (the corners must be cutted)



Detail of strap guide device



Detail of control panel



Officina Meccanica Sestese S.p.A.

Via Borgomanero, 44 - 28040 Paruzzaro (NO)

Tel. +39 0322 541411 Fax +39 0322 53157

www.omsspa.com

info@omsspa.com

As a part of our policy of continuous improvement, we reserve the right to alter design and specifications without prior notice. This brochure is for descriptive purpose only. Some of the items pictured in this brochure are optional and not standard equipment.