



STRAPPING

MOD.
MEGAJUMBO
REEL HOLDER
WITH ROTATING
TURNABLE

SPECIAL VERSION



 **Applications**



Bales

MEGA JUMBO Reel holder with rotating table

This special MEGA JUMBO reel holder has been designed to speed up strap replacement operations, especially in bale hay sector. The equipment is fitted with a motorized rotating table and a separated motorized storage dispenser. This

reel holder is suitable to be used with small arches and high production. It can load strap coils up to \varnothing 1150mm, with a maximum load of 1000 kg. Its rotary table is 250 mm high so the pallet of coils can only be loaded with a forklift.

Technical data

Power supply

Voltage 400 V (+/-10%) - 50Hz

Installed power ~ 1,1 kW

Coil data

Max. number loadable 3

Max. load weight 1000 Kg

Rotating table

Diameter \varnothing 1650 mm

Rotation speed 18 rpm

Coil size

Type of strap coil MEGA JUMBO

Dimensions OD 1150 x ID 406 x H 305 mm

Pack sizes

Coil type / Nr. of reels MEGA JUMBO / 3

Dimensions L 1150 x W 1150 x H 915 mm

Standard machine dimensions

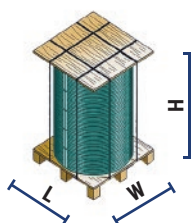
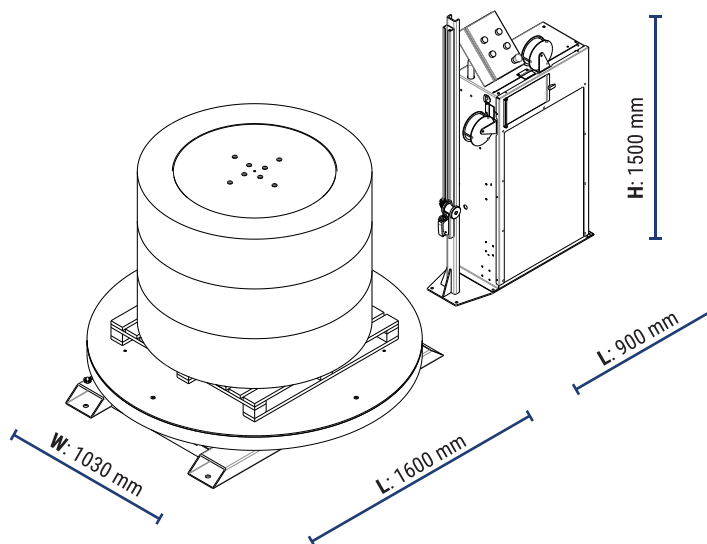

Detail of motorized storage dispenser and turntable

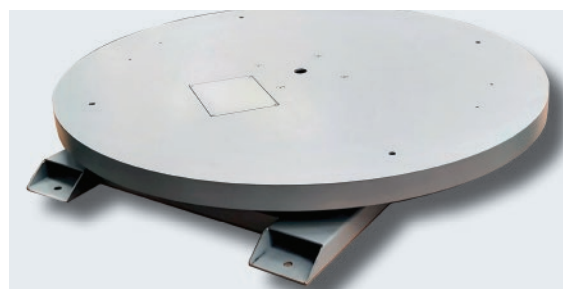

Detail of motorized rotating table



Officina Meccanica Sestese S.p.A.

Via Borgomanero, 44 - 28040 Paruzzaro (NO)

Tel. +39 0322 541411 Fax +39 0322 53157

www.omsspa.com

info@omsspa.com

As a part of our policy of continuous improvement, we reserve the right to alter design and specifications without prior notice. This brochure is for descriptive purpose only. Some of the items pictured in this brochure are optional and not standard equipment.