

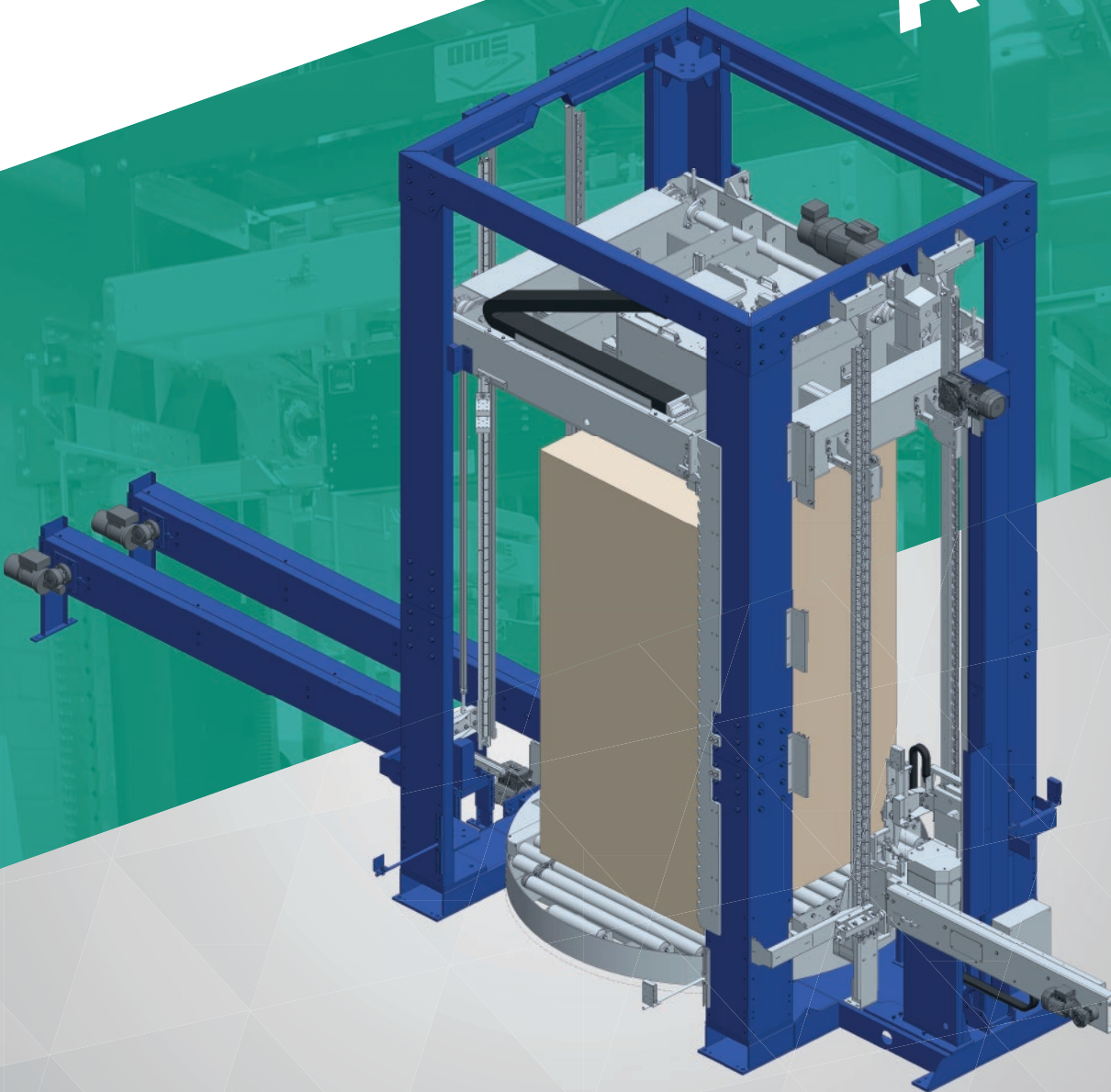

STRAPPING & WRAPPING

MOD.
AVFP2



 **Applications**



Cardboard

AVFP2

AVFP2_EN

Combination of an automatic vertical strapping and turntable wrapping machine the model AVFP2, is made to strap vertically products that must be pressed and well fixed during the transport and/or storage. The film-carrier incorporates a powered film pre-stretching unit to guarantee a minimum

film consumption and as well as a film breaking control system. Thanks to the welding & cutting device the cycle of this machine completely automatic. All the operating cycles (only straps, only wraps or both) of the machines and the individual devices may be programmed through a single operator panel.

Technical data

Power supply

Voltage	400 V (+/-10%) - 50Hz
Installed power	~ 6,5 kW

Air supply

Pressure	5,5 ÷ 7 bar
----------	-------------

Pressing

Power	2000 kg Max
-------	-------------

Strap

Type of strap	Polyester (PET) Polypropylene (PP)
Width	10 ÷ 15 mm
Thickness	0,6 ÷ 1,2 mm
Tensioning	0 ÷ 230 kg

Film coil

Type of film	Polyethylene (LLDPE)
Thickness	23 ÷ 40µ

Production

Capacity (complete cycle)	Up to 20 packs/hours
---------------------------	----------------------

Standard machine dimensions

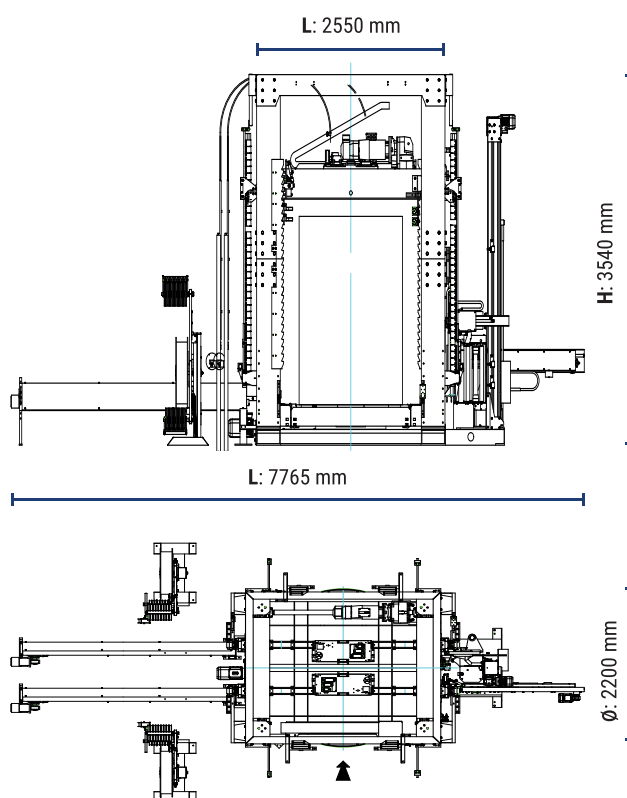

Pack size (standard machine)

Width	1400 mm Max
Height Min./Max.	500 / 2500 mm



Swords device



Welding & Cutting device



Officina Meccanica Sestese S.p.A.

Via Borgomanero, 44 - 28040 Paruzzaro (NO)

Tel. +39 0322 541411 Fax +39 0322 53157

www.omsspa.com

info@omsspa.com

As a part of our policy of continuous improvement, we reserve the right to alter design and specifications without prior notice. This brochure is for descriptive purpose only. Some of the items pictured in this brochure are optional and not standard equipment.